

Z3/Z32 With Optical Interface

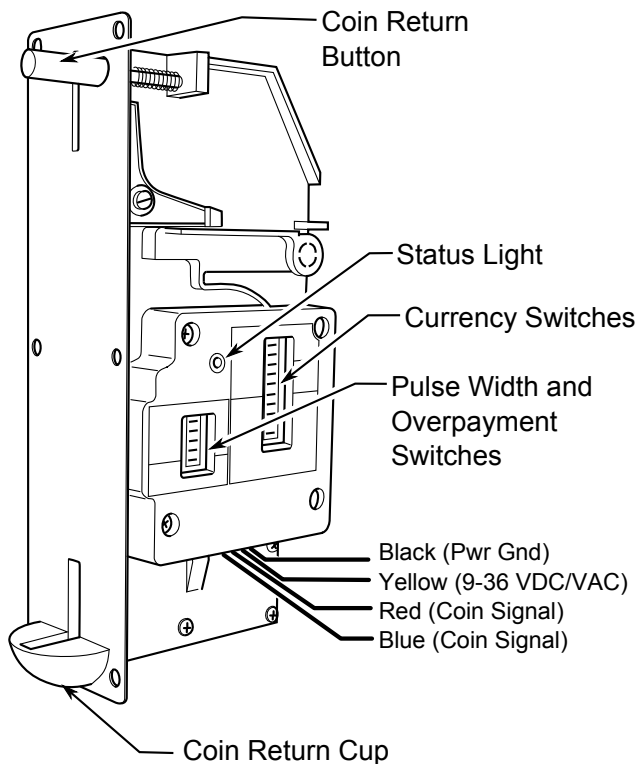

Installation Instructions



Features -

- Coin size range: 0.5" to 1.125" Preset at factory, not adjustable
- Acceptance: Z3 - Up to 2 different coins, 1 monetary value
- Acceptance: Z32 - Up to 4 different coins, 2 different monetary values
- Pricing Capabilities Built into Coin Acceptor
- Electronics Conformally Coated for Moisture Resistance
- DIP Switches Sealed with Rubber Boots

Applications -

- Self Serve Car Wash Bays
- Automatic Car Wash Payment Kiosks
- Coin Operated Vacuum Systems
- Coin Operated Air Machines
- Coin Operated Water Machines
- Coin Operated Batting Cages
- Coin Operated Parking Gates
- Most Outdoor Coin Operated Applications

Mounting The Coin Acceptor

	<p>Electrical Shock Hazard Disconnect power before servicing Replace all panels before operating Failure to do so can result in death or electrical shock</p>
--	--

- Mount the coin acceptor in the machine using the 6 - 3/16" Dia thru holes in the faceplate. In some cases, the coin return cup may need to be removed from the coin acceptor and remounted on the other side of the coin door on the machine.

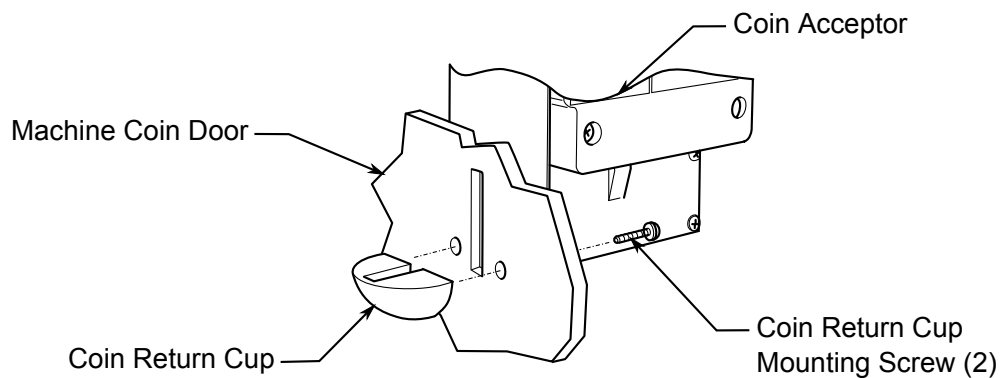

	<p>NOTE: Some machines do not include a hole for the coin return button. Imonex recommends that a 3/8" Dia hole be drilled in the machine coin door for the coin return button. The coin return button will help to eliminate coin jam related service calls. However, if needed, the coin return button can easily be removed from the acceptor.</p>
--	--

Z3/Z32 With Optical Interface



Installation Instructions

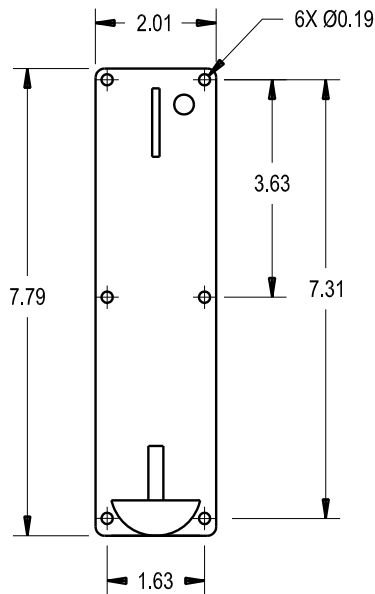

Mounting Dimensions

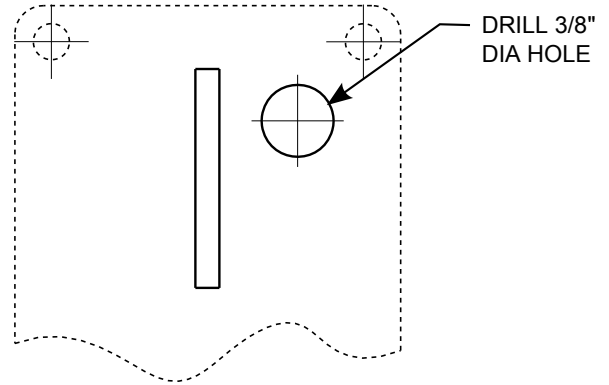

Machine Coin Door Return Button Hole Drilling Template

Electrical Shock Hazard
Disconnect power before servicing
Replace all panels before operating
Failure to do so can result in death or electrical shock

Typical Vacuum / Air Application Wiring

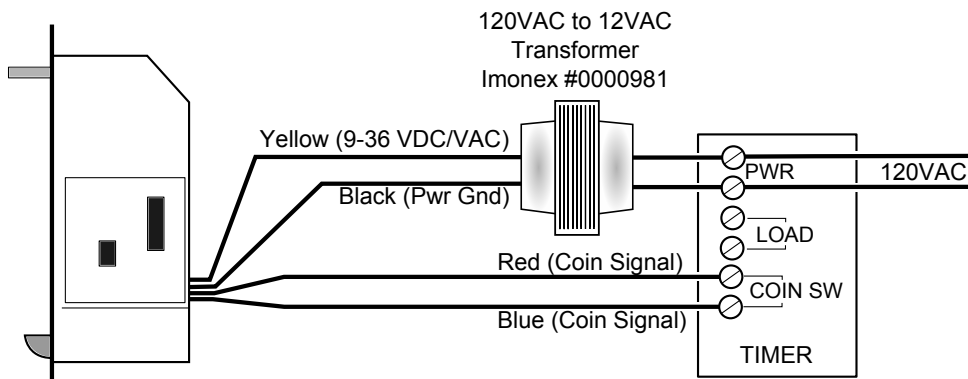

Typical Wash Bay Application Wiring

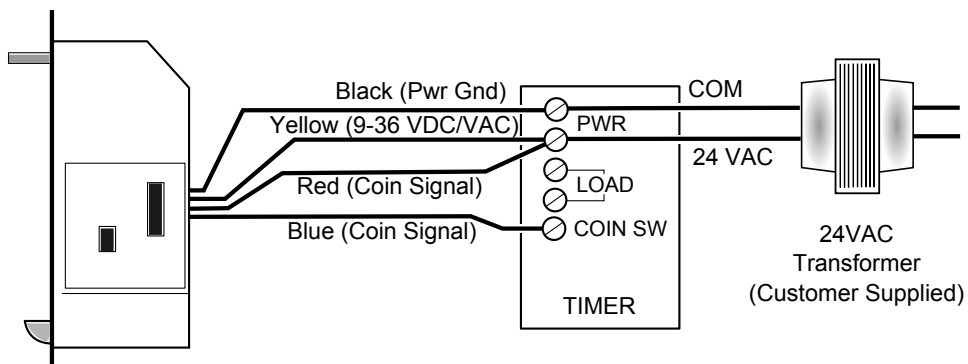

Z3/Z32 With Optical Interface



Installation Instructions



Replace all DIP switch covers after setting switches
 Do not use a lead pencil for setting the switches. The graphite may cause switch problems.

Setting Coin Values - Used on all applications

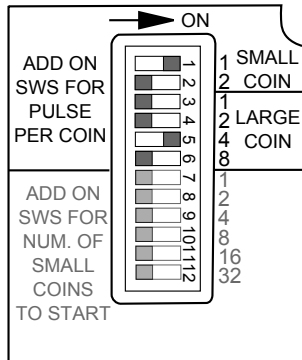

- The Coin/Token values are set at the factory and should not need to be changed unless using a token.
- Coin/token values are set according to the number of coins switch pulses sent by the coin acceptor for each coin size.
- Two coin/token values can be set, one for the Smaller Diameter Coin, and one for the Larger Diameter Coin.
- Set DIP switches 1 thru 2 for number of coin switch pulses for the Smaller Diameter Coin.
- Set DIP switches 3 thru 6 for number of coin switch pulses for the Larger Diameter Coin.
- Pulse values are labeled on the cover beside the switch number. The labeled value corresponds to the number of pulses for each coin size and are additive.
- Example: For a U.S. Quarter / Dollar acceptor, set the smaller diameter coin for 1 pulse and the larger diameter coin for 4 pulses. As shown in the figure, switches 1 and 5 are set to "ON". In this configuration, inserting a Quarter will send 1 coin pulse. Inserting a Dollar will send 4 coin pulses.

Setting Number of Coins to Start (Pricing) - Used only on applications where machine does not have pricing capability. (Do not use this with a Timer that has pricing)

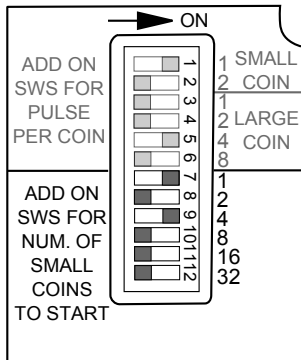

- Number of Coins to Start can be set by turning "ON" switches 7 thru 12.
- The Number of Coins to Start is labeled on the cover next to each switch. The switches are additive. For example, if switches 7 and 9 are "ON", the number of coins to start is set to 1+4=5.
- The Number of Coins to Start is the count of only the number of Small Diameter Coins.
- When any of the pricing switches are turned "ON", only 1 coin pulse is sent to turn on the machine when the set Number of Coins to Start has been entered into the acceptor.
- If pricing is not being used, switches 7-12 should be turned "OFF".

Setting Overpayment Handling - Used only on applications where machine does not have pricing capability

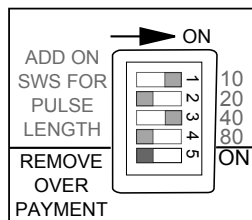

- If any of the switches on the Number of Coins to Start area are set to "ON", the Remove Over Payment Switch becomes active.
- If the user enters more coins than are required to start the machine, the acceptor can either keep the over payment amount and apply it to the next transaction, or clear the amount after 10 minutes.
- If the Remove Over Payment switch is "ON", the acceptor will clear any extra credits after 10 minutes. If "OFF", it will keep the extra credit for an unlimited amount of time.

Setting Pulse Length - Used on all applications

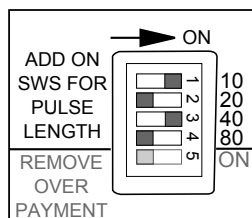

- The length of the coin pulse is adjustable with the left most DIP switch. Often problems with missed credits are related to the pulse width length being either too short or too long for the device the acceptor is communicating with.
- The length of the coin pulse can be set between 10mSec and 150mSec.
- To set the coin pulse length, use switches 1-4. The pulse length values are labeled on the cover and are additive.
- For Example in the figure the pulse length is set to 10+40=50mSec. This is the most common setting and should work for most applications.
- If all the switches are "OFF", no coin pulse is sent.

Z3/Z32 With Optical Interface



Installation Instructions

Status Light -

DISPLAY		MEANING
	CONSTANT GREEN	Powered Up and Operating Normally
	SHORT RED FLASH	1 Coin Credit Pulse Being Sent
	LONG RED, SHORT RED, SHORT GREEN, SHORT GREEN	Coin Sensor Error

Troubleshooting -

- ⚠ The most common reasons for problems:**
- ~ Coin acceptor is not wired properly.
 - ~ DIP switches are not set correctly. (Switches are set at the factory and should not need adjustment unless pricing or special token values are being used).
- **Machine *does not* register credits when a coin is entered into the coin acceptor:**
- ~ Verify that power is turned on to the machine.
 - ~ Verify that the Status LED on the coin acceptor is glowing "GREEN", if not, goto "Status LED is not a constant Green" below.
 - ~ Insert a coin and verify that the Status LED flashes "RED" at least once, signaling a pulse is being sent, if not, goto "**Status LED *does not* Flash "RED" for credit**" below.
 - ~ If Status LED **does** flash "RED" for credit:
 1. Verify that the Red and Blue Coin Signal wires are connected properly.
 2. Verify that the Coin Pulse Length switches are set to 50mSec (switches 1, 3 "ON"). If setting is correct, contact the machine manufacturer to determine the correct pulse width setting for the application and set pulse width to that value.
 - ~ If still not working properly, contact Imonex.
- **Status LED *is not* a constant Green:**
- ~ If status LED is not glowing at all:
 1. Verify that the Black and Yellow power wires are connected properly.
 2. Verify that the voltage between the Black and Yellow power wires is between 9 and 36V AC or DC.
 3. If all checks are good, then contact Imonex.
 - ~ If status LED is flashing Red, Red, Green, Green, a coin sensor error has occurred:
 1. Check for a coin jam in the acceptor.
 2. Turn power to the acceptor off and back on.
 3. If still not glowing constant Green, contact Imonex.
- **Status LED *does not* Flash "RED" for credit:**
- ~ Check that the DIP switches are set properly. If all of the Small Coin or Large Coin, Pulse Per Coin switches are set to "OFF", credit will not be sent for the coin with the switches off.
- **Coin acceptor sends out only 1 pulse after inserting several coins, but pricing is not being used:**
- ~ Verify that all of the Number of Small Coins to Start switches (7 thru 12) are set to "OFF".
 - ~ Check that all electrical connections are tight.
 - ~ Check that the voltage to the coin acceptor is between 9 and 36V AC or DC.
 - ~ Contact Imonex.
- **To reset coin acceptor turn power off and back on**

Maintenance -

- The acceptor should be cleaned periodically with soap and water. Clean the acceptor by opening the gates, and wiping the plastic surfaces clean with a damp rag. Blow the acceptor dry with compressed air after cleaning.

Specifications -

- Coin size range: 0.5" to 1.125" Preset at factory, not adjustable
- Acceptance: Z3 - Up to 2 different coins, 1 monetary value
- Acceptance: Z32 - Up to 4 different coins, 2 different monetary values
- Supply Voltage: 9-38VDC or VAC, 50/60Hz
- Current Draw: 50mA Max
- Coin Switch Voltage Rating: 350VAC/VDC Max
- Coin Switch Current Rating: 120mA Cont., 350mA Peak@10mSec
- Coin Switch Pulse Width: Adjustable 10-150mSec
- Coin Switch Time Between Pulses: 200mSec
- Coins to Start: 1 - 63
- Overpayment Clearing Delay: 10Min (If Overpayment Switch is set to "ON")
- Operating Temperature: -20 to 120 Deg. F.
- Operating Humidity: 0-100%
- Electronics Conformally Coated for Moisture Resistance
- DIP Switches Sealed with Rubber Boots